



SERVICE BULLETIN

Classification: RS03-008a	Reference: NTB04-003a	Date: March 17, 2004
------------------------------	--------------------------	-------------------------

2004 TITAN AND ARMADA; AIR BAG LIGHT ON CODE B1023 STORED

This bulletin updates NTB04-003 This version amends the Applied Vehicles.
Please discard all paper copies of the earlier version.

- APPLIED VEHICLE:** 2004 Armada (TA60)
2004 Titan (A60)
- APPLIED VIN:** Armada built before 5N1AA08B(*)4N 710033
Titan built before 1N6AA07A(*)4N 503607
- APPLIED DATE:** Armada built before October 30, 2003
Titan built before November 25, 2003

IF YOU CONFIRM:

- The "AIR BAG" warning light is ON, **with**
- DTC "Passenger Air Bag Indicator Circuit" (B1023) stored, **and/or**
- The PASSENGER AIRBAG "Status Lamp" (see Figure 1) does not come ON (it's inoperative),

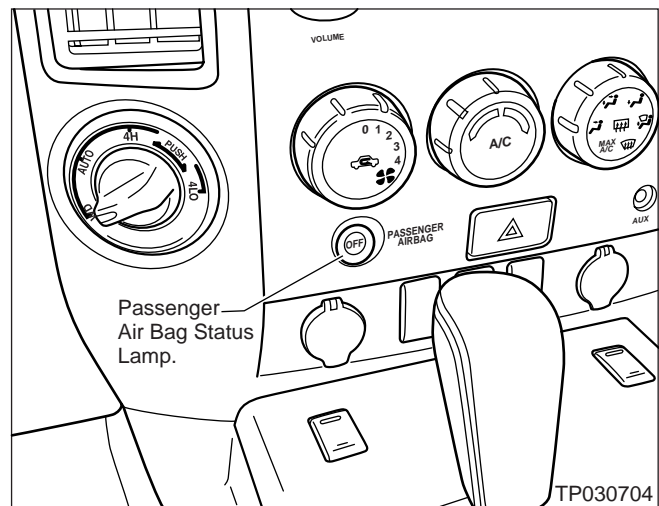

Figure 1

ACTION:

- Replace the Status Lamp with the new one listed in the Parts Information.

IMPORTANT: The purpose of "ACTION" (above) is to give you a quick idea of the work you will be performing. You **MUST** closely follow the entire Service Procedure (starting on page 2) as it contains information that is essential to successfully completing this repair.

Nissan Bulletins are intended for use by qualified technicians, not 'do-it-yourselfers'. Qualified technicians are properly trained individuals who have the equipment, tools, safety instruction, and know-how to do a job properly and safely. NOTE: If you believe that a described condition may apply to a particular vehicle, DO NOT assume that it does. See your Nissan dealer to determine if this applies to your vehicle.

PARTS INFORMATION

DESCRIPTION	PART #	QUANTITY
Warning Assy-Inst, A	25020-7S000	1

CLAIMS INFORMATION

Submit a Primary Failed Part (PP) line claim using the following claims coding:

DESCRIPTION	PFP	OP CODE	SYM	DIA	FRT
RPL Air Bag Warning Lamp	25020-7S000	RQ58AA	HC or ZE	32	0.4 hrs

SERVICE PROCEDURE

1. Write down the radio station pre-sets.

Pre-sets	1	2	3	4	5	6
A						
B						
C						

2. Shift the gear selector to the 1st gear position.

- Make sure the parking brake is applied.

3. Disconnect both the negative and positive battery cables, negative cable first. Then wait at least 3 minutes.

4. Pull the center dash “Switch Assembly” (face unit) loose from the dash (see Figure 2).

- There are 4 clips, one at each corner.
- Pull the switch assembly “straight-out” at the top and the bottom.

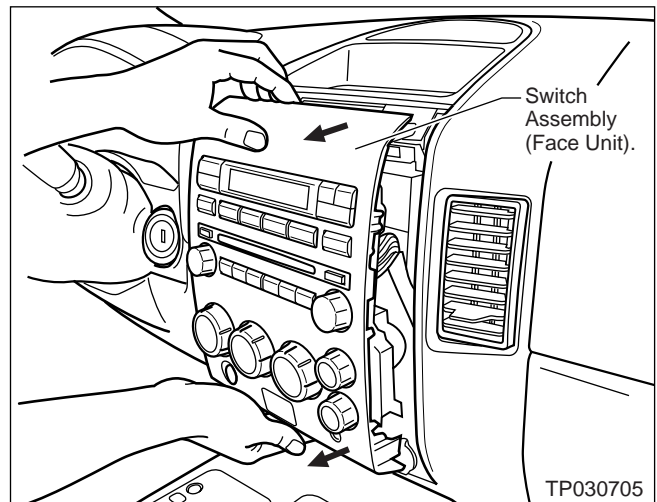

Figure 2

5. Mark the location of the two “white-8 pin connectors” with a felt maker so they won’t be mixed up (see Figure 3).

- These two white connectors are the same, except for the harness length and the number of pin slots used.

6. Disconnect each of the electrical connectors from the switch assembly.

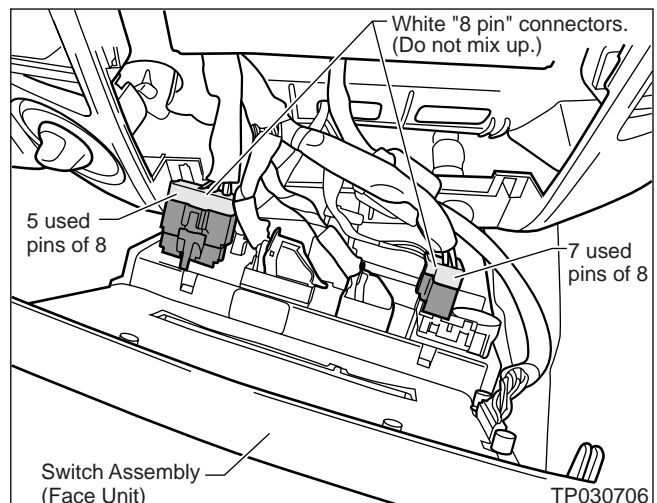

Figure 3

7. Remove the Status Lamp from the switch assembly.

- It's held on with two T10 torx screws.

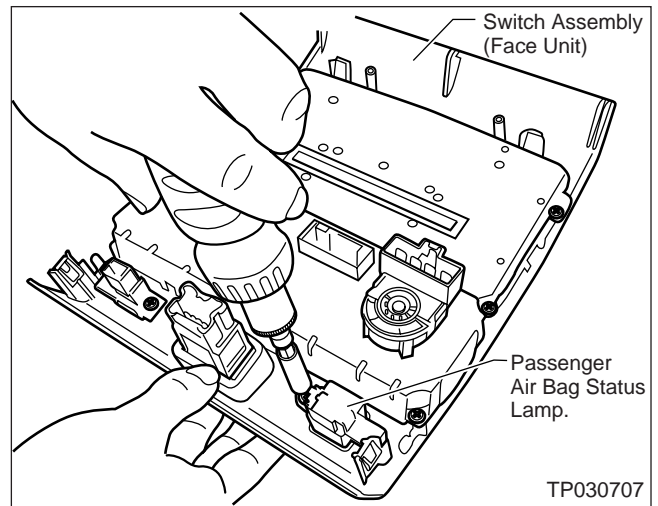

Figure 4

8. Install the new Status Lamp.

- Make sure it's installed correctly (see Figure 5). Note the square edge.

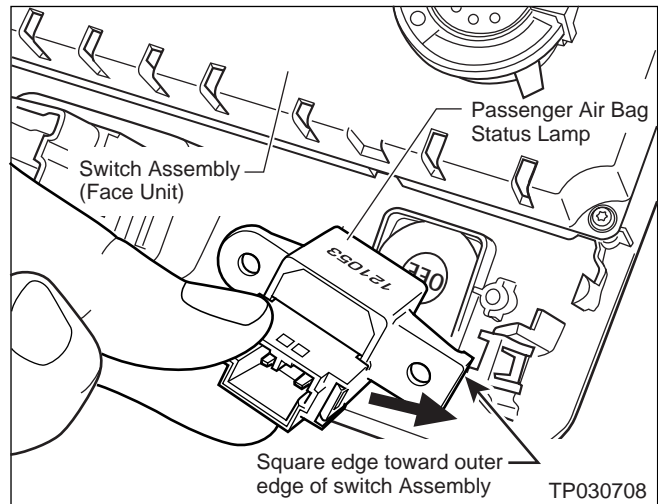

Figure 5

9. Reinstall the switch assembly in reverse order.

- **Do not** mix up the white 8-pin connectors (see Figure 3).

10. Reconnect the battery cables, positive cable first.

11. Reset the radio station presets.

12. Use CONSULT-II to make sure airbag DTC is erased from SELF-DIAG PAST.

